

OC-130 Oxygen Concentrator

The ON₂ Oxygen Concentrator is specifically engineered for medical oxygen gas generation. The OC-130 is designed to produce 515 litres/min of 95% oxygen (+/-1%) at 85 PSI delivery pressure. Oxygen Concentrators offer unmatched reliability and operating efficiency and are custom designed to provide an immediate reduction in cost and eliminate exposure to future increases due to increased usage or supplier price hikes. ON₂ Oxygen Concentrator systems are designed to be in compliance with the National Standard CAN/CSA-Z10083-08 and International Standard ISO 10083 for Oxygen Concentrator supply systems for use with medical gas pipeline systems.



OC-130 System in a room and ROCS, excluding Distribution Panel, secondary and reserve cylinders

The Advantages of ON₂ Vacuum Pressure Swing Adsorption

- Fast start-up and cycle times, which reduces overall power consumption
- Low power consumption – only 48.5 kWh
- Long life, low maintenance
- 3 min. recovery time for each cycle of oxygen concentration
- A smaller compressor utilizes less space
- Vacuum extraction more effectively removes waste Nitrogen gas
- The vacuum cycle removes all moisture from the sieve to maximize its service life



PROVIDING A SOLUTION TO YOUR OXYGEN NEEDS FOR OVER 25 YEARS

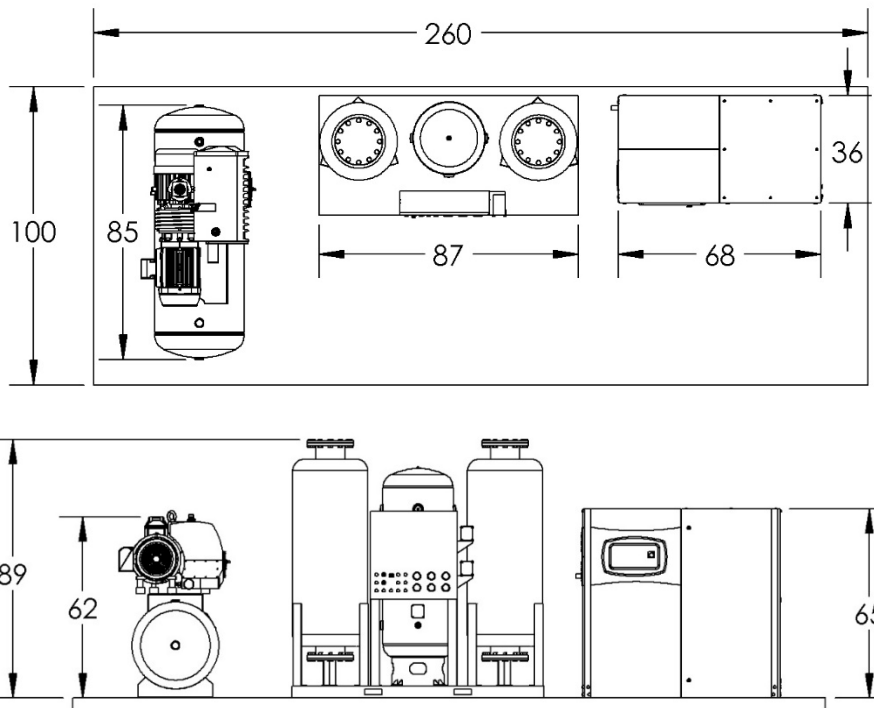

Standard Package

- **OC-130 Oxygen Concentrator**
 - Sound Level 83db
 - Heat Rejection 37500 BTU/Hr
 - Flow Capacity 515 LPM @ 85psig
 - Concentration 95% (+/- 1%)
 - Storage Tank 1060 gallons
- **Weight – 6000 lbs**
- **50hp Compressor**
 - Sound Level 70db
 - Heat Rejection 126000 BTU/Hr
 - Flow Capacity 230 CFM @ 125 psi
 - Air Receiver 240 Gallon
- **Operating Temperature +10 - + 40C**
- **Paramagnetic Analyzer**
- **Unit can be duplexed/triplexed for added reliability or additional capacity**

BENEFITS OF ON₂ OXYGEN CONCENTRATORS

- A LOWER COST OF SUPPLY / INFLATION PROOF
- NO RENTAL, ENVIRONMENTAL, OR TRANSPORTATION CHARGES
- NO WAITING FOR CRITICAL DELIVERIES
- INCREASED SAFETY INHERENT IN DESIGN
- AUTOMATIC OPERATION MEETS FLUCTUATING DEMANDS
- A SECURE AND DEPENDABLE GAS SUPPLY SOURCE

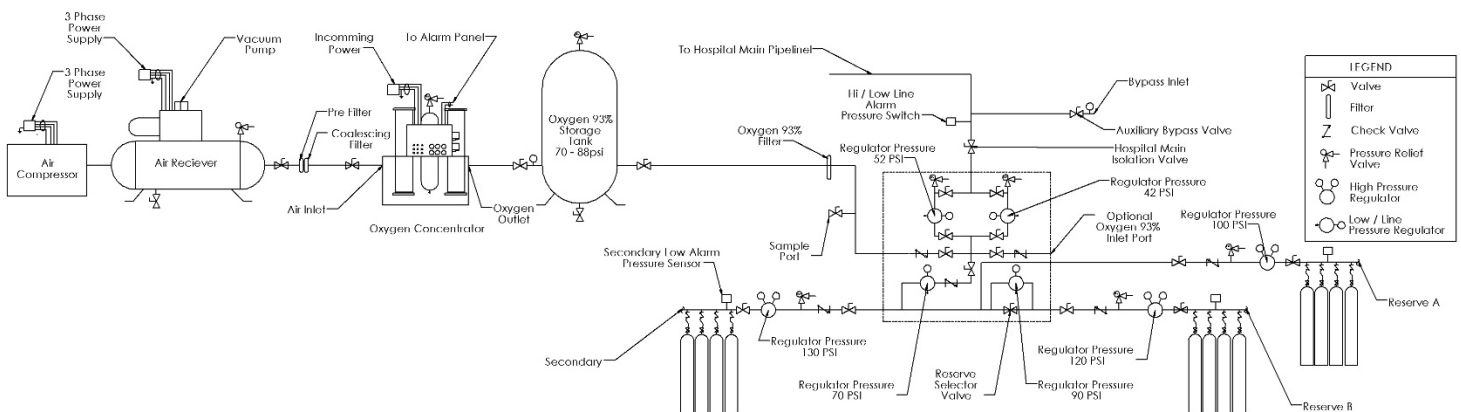

PROVIDING A SOLUTION TO YOUR OXYGEN NEEDS FOR OVER 25 YEARS